



MENTAL HEALTH CLASSIFICATION AND SERVICE COSTS
PROJECT

**Developing a
Casemix
Classification for
Mental Health
Services**

Summary

Bill Buckingham, Philip Burgess, Shane Solomon
Jane Pirkis & Kathy Eagar
Shane Solomon & Associates Pty Ltd
August 1998



Report of a Project funded by the
Department of Health & Family Services
under the National Mental Health Strategy
and the Casemix Development Program



ISBN 0 642 36730 2

© Commonwealth of Australia 1998

This work is copyright. It may be reproduced in whole or in part for study or training purposes subject to the inclusion of an acknowledgment of the source and no commercial usage or sale. Reproduction for purposes other than those indicated above requires the written permission of the Secretary, Commonwealth Department of Health and Family Services GPO Box 9848, Canberra, ACT 2601.

Additional copies of the report are available from the Mental Health Branch, Department of Health and Family Services GPO Box 9848, Canberra, ACT 2601

For further detail, see the Mental Health Branch website at:

<http://ww.health.gov.au/hsdd/mentalhe>

Full copies of the MH-CASC Project report are also available from the Mental Health Branch.

The opinions expressed in this report are those of the authors and are not necessarily those of the Commonwealth Department of Health and Family Services.

Published by the Commonwealth Department of Health & Family Services, Canberra.



SUGGESTED CITATION

Buckingham W, Burgess P, Solomon S, Pirkis J & Eagar K (1998) *Developing a Casemix Classification for Mental Health Services: Summary*. Commonwealth Department of Health and Family Services: Canberra

Foreword

MH-CASC is a project that breaks new ground in casemix research and development. Its simple objective, to create a casemix classification for specialised mental health services, was ambitious for various reasons.

Classification systems development in the past has been setting specific, and finding a recurring set of patient attributes that predict resource use in different settings has been very much uncharted waters. We do not find Diagnosis Related Groups (DRGs) being used to fund community episodes, or the Commonwealth Medicare Benefits Schedule to determine bed day reimbursement. Few casemix studies have tried to track patients across settings. In the absence of a single medical record and comprehensive case management systems, this tracking dimension created challenging logistics and data consistency issues.

The mental health community has been very sceptical of casemix in general, and DRGs in particular. The task of persuading sites to participate in the study was not taken as a given.

The core data items were not already collected. The only standardised clinical data was ICD-9-CM codes in the acute inpatient setting, and there were even inconsistencies between sites in this data set, particularly in relation to recording of patients as 'intended same day'. In the community and non-acute inpatient settings, there were no standardised sets of patient attribute data that could be peeled off existing patient information systems. All data items collected were new, and staff had to be trained and encouraged to add these data collection tasks to an already pressured workplace.

Finally, MH-CASC was ambitious because it was assumed, in the mental health sector, that there is a pattern in the way people with mental disorders are treated in specialised mental health services, and that this pattern has something to do with patient attributes or needs. The reality may be that provider variation is so dominant that there is little about the 'case' which can predict resource use.

So it is important to restate why, under the National Mental Health Strategy and Casemix Development Programs, the Commonwealth Department of Health & Family Services allocated substantial resources to such an ambitious undertaking over a three year period between 1995-98.

Firstly, the National Mental Health Strategy vision is that specialised mental health services will be part of the mainstream health system. Whilst the Australian health system has progressed towards casemix funding of acute inpatient services, Australian National DRGs (AN-DRGs) had not gained wide acceptance in the mental health system, both for clinical and technical reasons. At a minimum MH-CASC sought to test the clinical view that other factors besides diagnosis, such as severity and functioning levels, could better predict resource use in acute inpatient settings.

Secondly, even if we could obtain an acceptable classification and activity funding system for acute inpatient settings, we might then create distorted payment incentives. With community mental health services continuing to be funded on a fixed basis, regardless of the level and type of patients treated, the incentive would be to hospitalise because this would generate greater revenue for the health service.

Thirdly, the clinical view is that there is a high level of substitutability between mental health service settings. Many people once resident in the stand alone psychiatric hospitals are now living in community settings, with the support of community teams, and acute inpatient units when admission to hospital is needed. The MH-CASC aim of developing a classification that can be used across settings would create the incentive for substitutability. If a person can be kept out of hospital, then these savings can be available to build up community services to prevent unnecessary hospitalisation.

This underpins the National Mental Health Strategy principle that specialised mental health services should be integrated, to promote continuity and substitutability across settings. A key aim of MH-CASC

was to create a classification that can support the integration principle.

Fourthly, there was a perceived need to improve one of the poorer performing sets of AN-DRGs.

These then were the ambitions. What about the results?

Detailed socio-demographic and service use data on all patients attending one of 22 integrated mental health services (18 public sector and 4 private sector) between 1 September and 30 November 1996 were collected for the MH-CASC project. Data were collected on approximately 18,000 patients. This project studied about 25% of Australia's specialist mental health sector, a scale with neither Australian nor international precedents.

I would like to acknowledge the cooperation and participation of all those involved. Without their efforts the project would not have been possible.

This document presents a brief report on the findings of the study. I commend the report to you.

What MH-CASC studied is a good reflection of the current mental health system. The project found that there is an underlying clinical logic as to which patients receive more or fewer resources, but the pattern is weakened by provider factors. It is reassuring that the level of services received by patients is related to the severity of their conditions, but clearly, it would be better if the 'clinical/patient signal' was stronger.

This cannot happen, however, until there is greater consistency between clinicians about which treatments are most effective for which patients. One issue for the next period of mental health reform in Australia is how such consistency will develop 'naturally' and what the leadership role of mental health policy makers is in promoting 'good practice'.

Implementing some casemix monitoring system is a fundamental step. Protocols that are about 'cost effectiveness' cannot begin until we have a way of talking about cases that blends data on costs, patient

characteristics and service providers. Such a system must cover the whole range of services funded in mental health, as was done in the MH-CASC study. Any assessment of the MH-CASC classification needs to consider this advantage, in comparing the classification with the current AN-DRG mental health casemix model.

The MH-CASC classification also has the advantage of advancing some other important elements of the mental health agenda – such as promoting a focus on outcome measures, and strengthening treatment in community settings. It is arguable that any casemix system that does not advance the bigger issues of mental health services development is of limited value to providers, policy makers and practitioners alike. It is worthwhile reiterating what the Secretary of the Department of Health and Family Services, Mr Andrew Podger, said when opening the 1996 Casemix conference: *“The issue we now need to concentrate upon is the future direction of casemix and its role in improving the focus of the health system on patient outcomes and better cost management”*. The significance of this message is even stronger today.

At this stage, the Commonwealth Mental Health Branch is releasing the MH-CASC Project report for widespread review and discussion.

In its current form, the classification is likely to be useful as a management and clinical information tool that can inform funding decisions by providing more information on who is receiving mental health resources. This would allow it to be exposed to the necessary clinical modifications and begin to focus funding discussions on the important issues - care for patients.

Nothing will happen in this country until a lead is taken by one or more of the jurisdictions, which fund the services. The Commonwealth has an important part to play in supporting initiatives, and will consider how to best resource these under the Second National Mental Health Plan. The real impetus, however, now lies with the States and Territories.

I am convinced that mental health will lose the running unless it develops a coherent funding plan that embraces some form of 'casemix'. This needs to be combined with other tools, like population funding and, in some circumstances, grant funding based on agreed benchmarks. Most importantly, it needs to be put in a quality and outcomes framework.

We need a start, and as a first version system, MH-CASC offers us a platform to build on.

A handwritten signature in black ink, appearing to read 'Harvey Whiteford', enclosed within a hand-drawn oval.

Dr Harvey Whiteford
Director of Mental Health
Commonwealth Department of Health and
Family Services
Canberra, Australia
August 1998

Contents

Foreword	1
Overview	7
Background	9
Project aim and scope	9
Study methodology	9
Clinical attributes	10
Resource use	11
Overview of the dataset	12
Episode definitions used for class finding	13
Variation in the cost data	15
Variation in the clinical measures	15
The MH-CASC Classification Model	17
Adult Completed Inpatient Episodes	18
Adult Ongoing Inpatient Episodes	20
Adult Community Episodes	22
Child and Adolescent Completed Inpatient Episodes	24
Child and Adolescent Community Episodes	24
‘Bundled Episodes’	26
Summary of patient cost drivers	26
Comparative performance of the MH-CASC Classification Model	27
The role of provider factors	28
Implications for funding and the National Mental Health Strategy	30
The suitability of the MH-CASC classification for application	30
Implications for data collection	32
Further development of the classification	32
Suggestions for funding model design	35
Strengthening the signal	35
The MH-CASC Project Team	37
Terminology	38

Terminology

This summary is a short overview of the Mental Health Classification and Service Costs (MH-CASC) Project. The summary has been prepared for a general audience, but due to the nature of the project, it includes technical terms that may not be familiar to a number of readers. Short definitions of some of the key terms are presented at the end of this report.

Overview

This booklet summarises the findings of the Mental Health Classification and Service Costs (MH-CASC) Project, a major service utilisation study conducted under the National Mental Health Strategy. The aim of the Project was to develop the first version of a national casemix classification, with associated cost weights, for specialist mental health services that:

- is consistent with the National Mental Health Strategy;
- can be used to classify mental health patients in the various treatment settings; and
- includes an appropriate number of casemix classes, each of which comprises consumers with similar clinical conditions and similar resource use needs.

The MH-CASC Project commenced in 1995 and continued over the next three years. The study collected detailed clinical, socio-demographic and service use data on approximately 18,000 consumers attending specialised mental health services. Clinical measures were selected to cover the broad domains of diagnosis, clinical severity and level of functioning (disability). The sample was significant, covering 25% of Australia's private and public mental health services. Service utilisation data were provided by approximately 4,500 staff who maintained daily diaries of all activities over the three month period 1 September to 30 November 1996. The scale and complexity of the study has no international precedent.

The Project found that there is an underlying episode classification, not just in inpatient services but also in community mental health care. The level of service provided to patients does in fact bear a clinically and statistically logical relationship to the patient's clinical status. However, the relationship between clinical factors and cost is often confounded by variations in the practice of different providers. Some of these provider factors may be structural or financial, and others may be under the control of individual clinicians. Further work is required to disentangle these factors.

The Project Team recommends a first version casemix classification model which includes 42 patient classes - 19 for community episodes, and 23 for inpatient episodes. While explanation of variance was found to be lower than Australian National Diagnosis Related Groups (AN-DRGs) standards in the general health system, the overall explanation of variance of the classification is higher than that achieved using the AN-DRG mental health classes.

Adoption of this classification schema would require routine use of a small number of clinical scales, applied at periodic intervals. The classification may be used for both management information and funding purposes and has considerable potential to advance the National Mental Health Strategy. As a first version casemix classification, it will benefit from ongoing clinical refinement and further research.

The key questions addressed by the Project, and findings in relation to those questions, are summarised in Table 1.

Table 1: Answers to the key questions addressed by the Project

Key questions addressed by the Project	Summary of Project findings
<p>1. Is there a relationship between patient attributes, or need, and service costs?</p> <ul style="list-style-type: none"> • Do higher need patients cost more? • How do we classify patient need? • Is there a normative clinical pattern in Australia's specialised mental health services? 	<p>Higher treatment costs are associated with indicators commonly used to assess individual patient need such as:</p> <ul style="list-style-type: none"> • clinical severity; • level of 'psychosocial functioning'; • age; • diagnosis; and • dependency for activities of daily living. <p>No single measure is suitable to determine need. The classification uses a combination of instruments and measures that assess demographic, clinical and level of functioning characteristics. Similar measures are used in inpatient and community services.</p> <p>There is an underlying 'patient signal' upon which a casemix classification can be developed, but the costs being driven by 'casemix' are often confounded by the costs driven by provider variations.</p>
<p>2. Is the pattern sufficiently strong to use it for funding?</p> <ul style="list-style-type: none"> • Is it consistent with casemix statistical standards? • Is there clinical logic in the statistical pattern? 	<p>Ultimately a question for funders - is it better than what we have now?</p> <ul style="list-style-type: none"> • RIV competitive: Higher than the AN-DRG mental health classification but is restricted by limited cost variation between patients and is lower than the AN-DRG standards used in the general health system. • CVs for individual classes are lower than those for the AN-DRG mental health classification, indicating more homogeneous groups. CVs for all 42 classes are less than 1.0. • Sufficient numbers are in each class when translated to the national level. <p>The classification has clinical logic. For example:</p> <ul style="list-style-type: none"> • people in non-acute inpatient settings have higher levels of clinical severity and disability than those living in the community and those who use acute inpatient services; and • the costs go in the clinically expected direction.
<p>3. Can the classification advance the National Mental Health Strategy?</p> <ul style="list-style-type: none"> • Can the classification be used to reward continuity of care in the community, by: <ul style="list-style-type: none"> - reducing the separation of inpatient and community services? - facilitating the movement of patients between hospital and the community? • Would its use support integration and mainstreaming? • Does it give priority to high need groups? • Can it be used to promote a focus on consumer outcomes? 	<p>The classification covers both inpatient and community services. The variables driving costs in inpatient settings are also driving costs in the community but:</p> <ul style="list-style-type: none"> • the patterns of care are different, so • the importance of the variables differs across the two settings. <p>Adoption of this classification for mental health services may create challenges for mainstreaming but is consistent with a broader recognition that a single classification based on AN-DRGs is inappropriate for many health services, not just mental health.</p> <p>Integration would be facilitated by the use of a classification that covers both inpatient and community mental health care.</p> <p>The classification provides management and clinical information that can inform funding decisions by giving a greater focus on the different needs of those receiving mental health resources.</p> <p>The classification is built upon the use of measurement instruments explicitly designed for outcome measurement in mental health.</p> <p>Provides a basis for casemix-adjusted outcome measurement.</p>

Background

The bulk of public specialised mental health services are currently funded either on an historical basis or through specification of a range of 'inputs', such as number of beds and staff. Private mental health services are funded per bed day or occasion of service. Neither approach provides financial incentives for efficiency, quality, improved consumer outcomes, or for substitution of inpatient care by community-based care.

Under the Medicare Agreements between the Commonwealth, States and Territories, effective from July 1993 to June 1998, Australian Health Ministers agreed to move towards the establishment of a nationally consistent casemix-based management and information system, which could serve as the basis for alternative funding arrangements. Such funding schemes are believed to:

- be inherently fairer than historical funding because they pay health services on the basis of their activities, measured in terms of the number of patients treated and the type and severity of their conditions;
- have superior incentives for productivity; and
- reinforce best practice (e.g., reduce excessive hospital stays).

Achieving this potential is contingent on the tools available for classifying and setting prices for services. Several classifications exist, but none are regarded as being suitable for the Australian mental health care setting. AN-DRGs, the classification adopted in acute inpatient settings in the general health sector, is based primarily on diagnosis and does not explain adequately the variation in the care needs of mental health consumers. Other classifications developed elsewhere perform poorly in terms of predicting resource use, or have an unwieldy number of classes. Another common feature of existing classifications, including AN-DRGs, is that they are limited to specific service settings (primarily acute or long-stay inpatient settings) and would thus provide an incentive to admit patients, a practice which would run contrary to the National Mental

Health Strategy's aim of treating people in the most appropriate setting, including in the community.

Project aim and scope

The MH-CASC Project aimed to determine whether clinical factors predicted service costs, and whether these could be used to build a patient classification that was both clinically meaningful as well as resource homogeneous. It addressed three key questions:

- Is there a relationship between patient attributes, or needs, and service costs?
- Is the pattern sufficiently strong to use it for funding?
- Can the classification advance the National Mental Health Strategy?

The study covered public specialised mental health services and specialised private hospital acute units. Private psychiatric practice was excluded from the costing aspect of the Project, but Medicare Benefits Schedule (MBS) data were sought on the use of private psychiatrists by study participants. Mental health services provided by general hospitals without specialised psychiatric units and by general practitioner services were outside the scope of the study.

Study methodology

Twenty two sites participated in the study, selected according to statistical and clinical criteria. Study sites represented approximately 25% of the Australian mental health sector in terms of inpatient beds, workforce numbers and expenditure, and were broadly representative of public and private sector services nationally. Data collection occurred over the three month period 1 September to 30 November 1996.

In total, the study sites collected data on 18,002 consumers over the study period. The study cohort covered all age ranges, and had roughly equal numbers of males and females, who received 20,553 episodes of care (5,449 in acute inpatient units; 1,055 in non-acute inpatient units; and 14,049 community). These episodes comprised a

total of 318,309 patient care days. The vast majority of consumers (90%) had one episode only, and a further 7% and 2% had two and three respectively.

Clinical attributes

From a review of the international literature and the recommendations of clinical panels, a number of patient attributes were identified as likely to have an impact on resource use. These are listed below, along with the specific measurement instruments used.

- Psychiatric diagnosis, using a tailor-made system of 16 major categories and 61 individual codes based on ICD-10 clinical terms
- Severity and level of functioning, which were measured by:
 - The Health of the Nation Outcome Scales (HoNOS) (all patients in Adult services).
 - The Abbreviated Life Skills Profile (LSP) (all patients in Adult services).
 - The Resource Utilisation Groups – Activities of Daily Living (RUG-ADL) (patients aged over 65 or with chronic organic brain syndrome in Adult services).
 - The Resident Classification Instrument (RCI) Behaviour Scale (patients aged over 65 or with chronic organic brain syndrome in Adult services).
 - The Health of the Nation Outcome Scales for Children and Adolescents (HoNOSCA) (all patients in Child and Adolescent services).
 - The Children’s Global Assessment Scale (CGAS) (all patients in Child and Adolescent services).

- Focus of care, which classified the patient’s primary need for treatment and the treatment objective as acute, functional gain, intensive extended or maintenance.
- Legal status, which identified whether a consumer had received involuntary treatment at any point during the period rated.
- Factors influencing health status and contact with health services, which was assessed in Child and Adolescent services only, and gauged the degree of ‘complicating psychosocial factors’, such as contact with the juvenile justice system or the presence of a legal guardian, that required additional clinical input during the episode.

The data collection cycle revolved around the notion of an episode of care. To simplify data collection, an episode of care was defined by treatment setting. Movement to a new treatment setting was defined as a new episode of care, and triggered a new cycle of data collection. Three types of treatment setting were identified: Acute inpatient units, Non-acute inpatient units, and Community services.

Within each episode, there were three critical points in the patient attribute data collection cycle.

- At the beginning of an episode, socio-demographic data and information about the episode were collected.
- Every 14 days of the episode, repeat clinical ratings were made.
- At the end of the episode, a final clinical rating was made, and a small number of additional clinical items were collected.

Resource use

In order to provide information on resource use, staff recorded daily activities which could be attributed to specific patients, as well as non-patient attributable activities (teaching, training and research; consultation-liaison; services to unregistered patients; and community development). Any residual time in a given shift for a particular staff member was subsequently calculated and described as 'general time', which potentially included a wide range of activities, both clinical and non clinical.

Data on patients' use of private psychiatrists during the three month study period (as identified by Health Insurance Commission statistics) were also collected to supplement staff activity data provided by private hospitals included in the study.

'Core' costs (salaries, wages and on-costs for direct care staff, MBS costs for private psychiatrists' services provided to private inpatients, administrative infrastructure costs, overheads and goods and services) were distributed to two categories of 'products': (a) Patient care products; and (b) Non-patient care products. Prior to this distribution, labour costs were standardised to remove the substantial variation between

sites in hourly rates and reduce the overall influence of 'site' as a cost driver.

In the case of patient care products, costs were allocated to individual patients in relation to the time spent on patient attributable activities, according to a range of statistics and subsequently aggregated to form episode costs. Figure 1 provides an example of costed patient care days for a patient with multiple episodes.

With non-patient care products, costs were distributed to the four 'non-patient attributable activities' reported by staff. Total costs assigned to these four activities became separate 'final products'.

Figure 1: Costed patient care days for a patient with multiple episodes

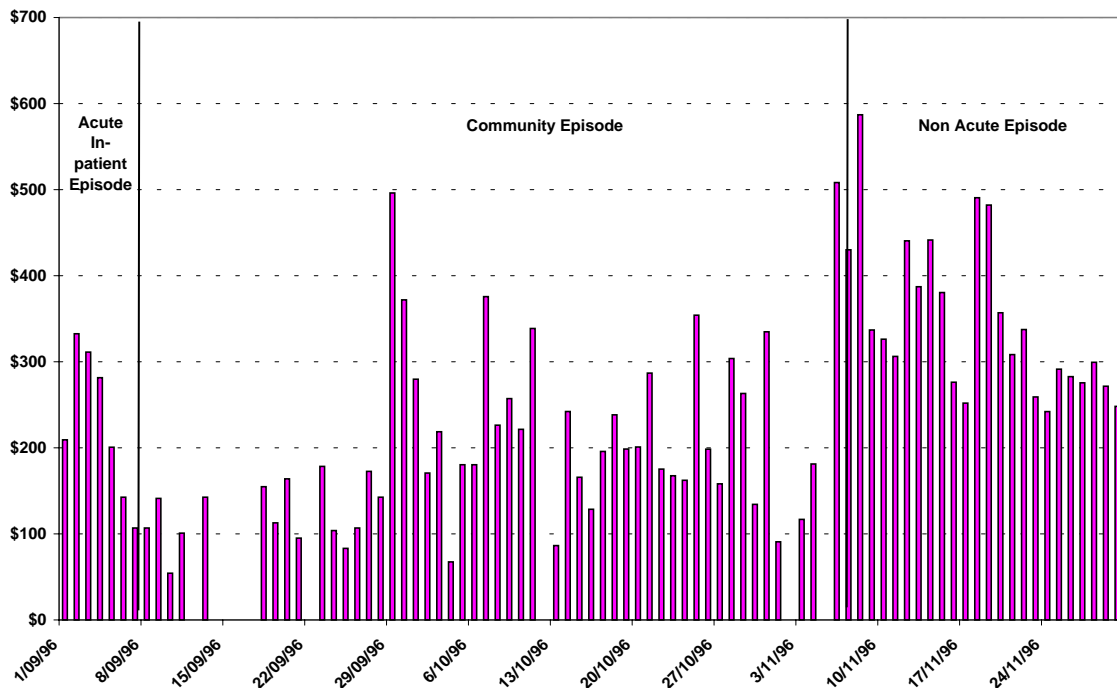

Overview of the dataset

Most patients in the study had significant histories of psychiatric treatment. Patients for whom psychiatric treatment commenced more than two years prior to the current episode accounted for 43% of total episodes. In 61% of episodes, the patient had at least one prior admission to a psychiatric inpatient unit. Only 14% of episodes were provided to patients who were reported to have no prior history of psychiatric care. The extent and type of prior psychiatric treatment varied between the episode types. Patients admitted to acute inpatient units had generally been in contact with mental health services for a shorter period of time than patients receiving non-acute inpatient or community care.

The most common diagnosis across all episode types was schizophrenia and related psychotic disorders, followed by mood disorders. However, particular diagnoses occurred more frequently in particular settings.

Approximately 4,500 clinical staff participated in the study. Collectively, these staff reported 1.3 million hours of activity, spread across 158,000 person days worked during the study period. Approximately 75% were nurses, and approximately 25% were based in settings primarily dedicated to providing community-based care.

Compliance with recording staff activity data was high, with activity reported for an estimated 87% of time worked by staff over the study period. Episodes in a small number of service areas where staff reporting compliance was low were excluded from the analysis.

Patient attributable activities accounted for 46% and non-patient attributable activities for 8% of time recorded by staff, with the residual 46% described as 'general time' (see Figure 2). Of the patient attributable time, 60% was spent on hospital or community health centre-based individual patient care, 10% on group based care, 9% on mobile treatment or support services, and 22% on "services on behalf of patients", defined as those services delivered on behalf of a person in their absence (e.g., interagency liaison, clinical notes). Of the

non-patient attributable time, 41% was spent on teaching, training and research, 26% on consultation-liaison, 24% on services to unregistered patients, and 9% on community development. Patterns of activity varied by labour class, setting and site.

Figure 2: Distribution of staff time between activity categories

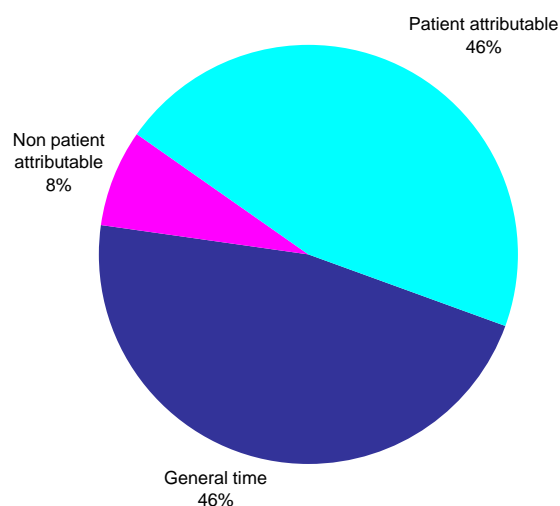

Total expenditure by sites during the three-month study period was \$82.2 million, 9% of which was allocated to 'out of scope' services. The majority of 'in scope' expenditure - \$65.8 million, or 88% - was directed to patient care, with the balance distributed across the four 'non-patient attributable' activities.

Salaries and related costs for clinical staff accounted for approximately two thirds of the total amount spent on patient care activities. Overhead and administrative infrastructure expenditure made up the remaining one third of patient costs. These figures varied substantially from site to site, and between different settings.

Nursing salary and wage related costs comprised 70% of expenditure on clinical staff providers, followed by medical staff at 17%.

Forty eight per cent of patient care costs were directed to acute inpatients, 29% to non-acute inpatients and 23% to community patients.

Costs per day of patient care varied significantly between setting types, ranging from an average of \$95 in the community to an average of \$334 in the acute inpatient setting. Within each setting, there was considerable variation across sites. Total episode costs were highly correlated with patient attributable time recorded by clinical staff.

Episode definitions used for class finding

Casemix classification systems are typically tied to specific treatment or care events, referred to as 'episodes of care'. A major conceptual issue to resolve in the study was how to define episodes of care in a way that was congruent with the range of illnesses treated by specialised mental health services. In contrast to most classification systems which only deal with one episode type or 'funding product', the MH-CASC Project had the difficult task of covering numerous potential episode types, because its scope crossed the traditional inpatient/community and acute/non-acute boundaries.

The low level of multiple episodes by individual patients over the three-month period, described above, was unexpected. This feature of the data limited the project ambition to explore concepts of 'bundled episodes' across settings. Class finding was therefore primarily concentrated on within-setting episodes, with bundled episodes considered subsequently on an exploratory basis.

A key issue was how to deal with incomplete episodes, defined as those which started and/or ended outside the 3 month study frame. These accounted for 71% of total patient care costs reported by study sites. It was not considered appropriate to exclude them, because short and long term cases are a feature of the mental health sector.

Review of the data suggested that a classification based only on completed episodes was feasible for the majority of inpatient episodes. These typically occur in units referred to as 'acute units' and have relatively short length of stays. However, the definition of episode for community needed to recognise that the majority of

patients are under relatively longer term ('ongoing') care, as are a small but significant group of patients treated in inpatient units.

For both the community and longer term inpatient episodes, analysis of the study data indicated that episodes were best defined as a fixed periods of care (e.g., 1 month, 3 months etc). This recognises the ongoing nature of mental illness for many people under care and that the major cost difference between patients is in the intensity of care received over a given period rather than the length of time the person is considered to be 'under care'. For example, in the community, 20% of patients treated in the community were seen on 2 days or less over the 3 month period. By contrast, the top 20% of patients were seen on 14 or more days over the same period. Defining an episode of care in the community as the total care received over a given period reflects these differences, and was regarded as a more appropriate approach than classifications based on the cost of each occasion of service.

For the class finding analysis, costs for community and ongoing inpatient episodes were scaled to 8 week periods of care for logistic reasons. However, these costs (and associated cost weights) could be adjusted to any period when applied in a funding system.

In summary, three setting-specific episode types were defined for analysis purposes as shown in Table 2.

Table 2: Episode types used for developing the MH-CASC classification

Episode Type	Unit of Counting
Completed Inpatient Episodes	Total Episode Cost
Ongoing Inpatient Episodes	8 week period cost
Community Episodes	8 week period cost

Episodes defined as ‘intended same day’ by hospitals participating in the study were examined, and found to be more similar to community days of care than inpatient days, in terms of cost and type of care provided. These were counted as components of community episodes.

Separate classification analyses were conducted for adult mental health services and child and adolescent mental health services, with the exception that a classification was not possible for child/adolescent ongoing episodes due to the low volume of cases.

For the exploratory analysis of adult ‘bundled episodes’, the Project Team conducted initial analyses that could provide a foundation for future work. The approach aimed to explore whether a classification could be developed that explained the total costs received by all patients over the study period, regardless of the setting in which they were treated. In this approach, the

episode was defined as an 8 week period of care, similar to the definitions used for Community and Ongoing Inpatient Episodes, but where costs of the treatment received in all settings is pooled. This approach to episode definition allows for the prospect of a capitated casemix model of funding, where a service provider would be funded for providing comprehensive care to particular patient classes over a defined time period.

A total of 16,611 setting-specific episodes were retained in the class finding analysis, with 72% of these being community episodes. For the exploratory ‘bundled episodes’ analysis, 8,067 adult episodes were included. Table 3 presents summary descriptive statistics for each of the episode types.

Table 3: Summary resource use statistics on the analysis cohorts

	Adult Cohorts				Child & Adolescent Cohorts	
	Completed Inpatient Episodes	Ongoing Inpatient Episodes (8 week period)	Community Episodes (8 week period)	‘Bundled Episodes’ (8 week period)	Completed Inpatient Episodes	Community Episodes (8 week period)
Number of Episodes - Trimmed	3,613	949	9,806	8,067	145	2,098
- Untrimmed	3,426	919	9,096	7,244	139	1,956
Av. Episode Cost*	\$3,900	\$13,722	\$526	\$1,007	\$6,048	\$377
Av. Length of Stay/ Treatment Days*	12.4	54.1	6.3	10.4	16.6	4.1
Av. Cost per Treatment Day*	\$331	\$254	\$94	\$77	\$415	\$95
Av. Total Episode Time (hrs)*	31.8	110.5	5.6	23.8	46.4	4.1
Av. Time per Treatment Day (hrs)*	2.6	2.0	0.9	1.1	3.1	1.0

Note: These statistics refer to trimmed data.

Variation in the cost data

A key feature of the cost data was the relatively small variation between patients in terms of episode costs, indicated by relatively low coefficients of variation (CVs). Most variation occurred in community episodes, but even here the distribution of costs was limited (CV=1.22 for adults; CV=1.24 for children/adolescents).

By comparison, the overall variation in the untrimmed AN-DRG dataset collected in the wider health system (CV=3.3) is approximately three times that of the MH-CASC sample. Even at the individual Major Diagnostic Category (MDC) level, the lowest CV (CV=1.2 for MDC 14: Pregnancy, Childbirth and Puerperium) is greater than the largest CV of the three MH-CASC inpatient cohorts (CV=1.01 for adult completed inpatient episodes).

In summary, there is less variability between patient costs in the mental health system than there is in the broader health system. This is hardly surprising. An important implication of the limited variation in the MH-CASC episode costs is that the application of classification tools could only be expected, at best, to achieve a modest reduction in variance (RIV) as there is less variance to explain.

Variation in the clinical measures

Adult patients in ongoing inpatient episodes were rated as more severe in their overall level of symptoms and disability than their counterparts in completed inpatient episodes and community episodes. Patients in ongoing inpatient care showed higher average scores on all HoNOS items (with the exception of Suicidal behaviours, Substance abuse and Depressed Mood), and on all LSP items. Patient profiles in Completed Inpatient and Community episodes were less differentiated, although those in Completed Inpatient episodes had slightly higher HoNOS scores than those in Community episodes on the Aggression, Suicidal behaviours, Substance abuse,

Hallucinations and delusions, and Depressed mood scales. This may reflect limitation in the extent to which the scales are able to differentiate degrees of severity in clinical conditions, or suggest that there is still considerable scope for substitutability between community and acute inpatient settings.

Within each of these cohorts, however, there was considerable variation in HoNOS and LSP scores.

Figure 3 compares the HoNOS profiles of patients in the three adult setting-specific episode types.

For child/adolescent patients, Completed Inpatient and Community episodes were similar in their clinical profiles, although the completed inpatient cohort tended to score slightly higher on some HoNOSCA scales: Self-injury, Substance Abuse, Hallucinations and Delusions, Somatic Symptoms, Emotional Symptoms, Family Life, School Attendance and Accommodation. Figure 4 compares the HoNOSCA profiles of child and adolescent patients in community care with those in Completed Inpatient episodes.

Figure 3: HoNOS Scores for Adult Community, Completed Inpatient and Ongoing Inpatient Episodes

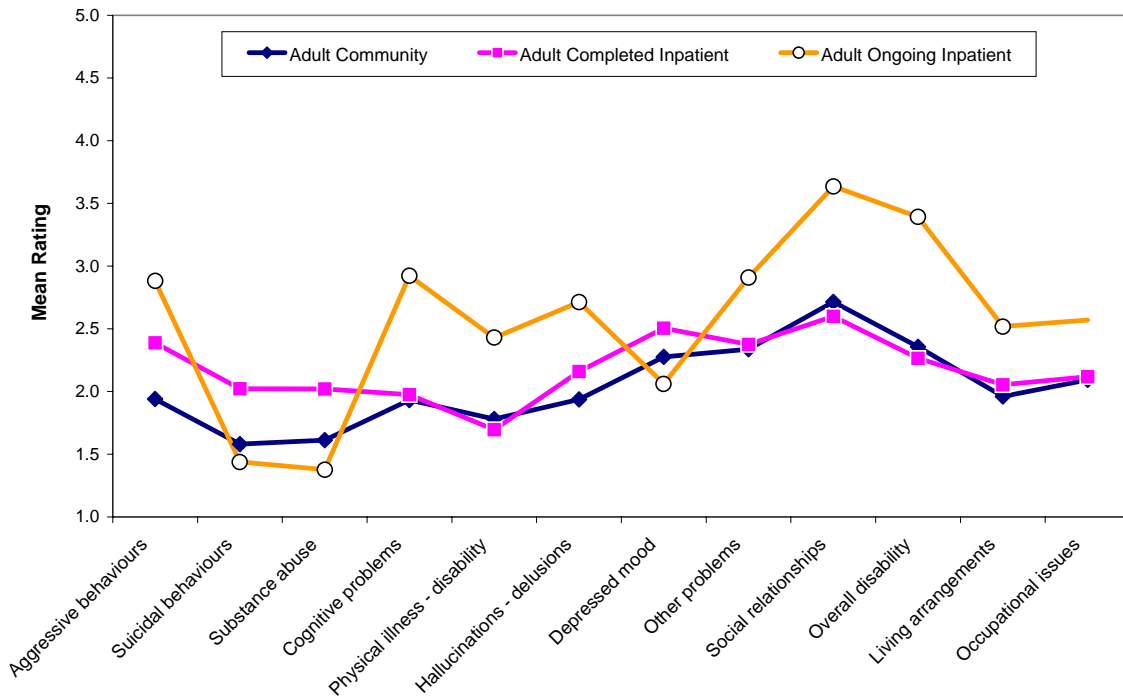
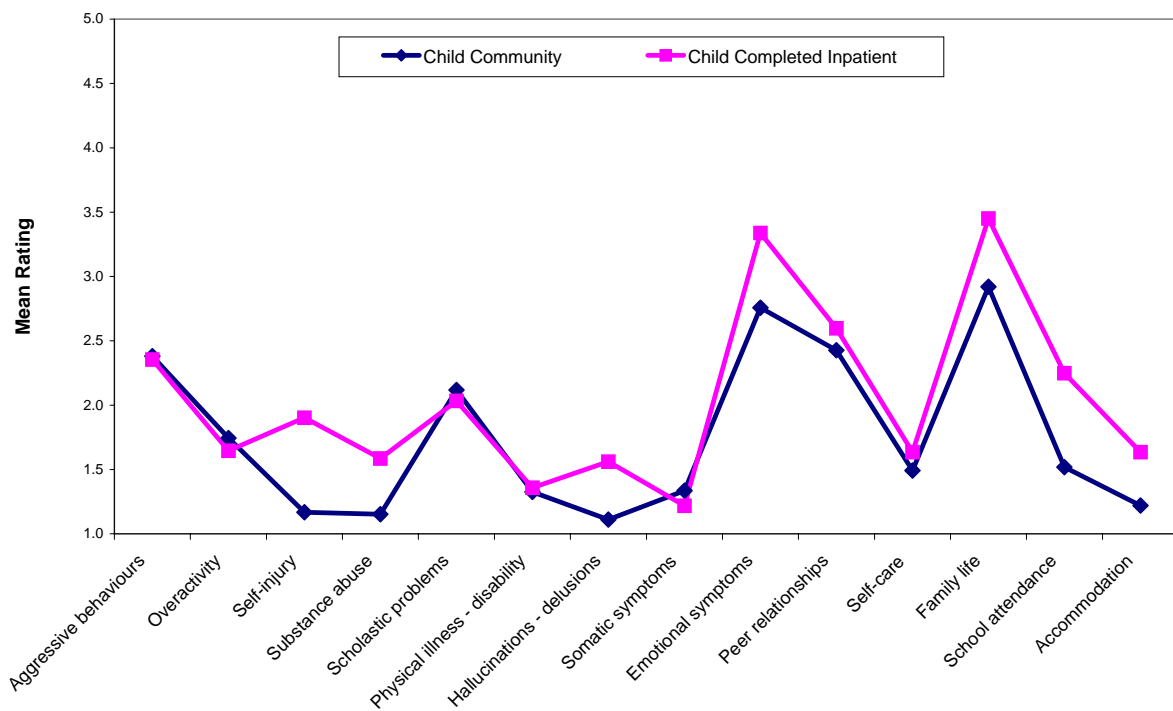

Figure 4: HoNOSCA Scores for Child/Adolescent Community and Completed Inpatient Episodes



The MH-CASC Classification Model

Development of the MH-CASC classification followed four criteria.

1. *Use of patient related variables to explain cost.* A casemix classification should define patient classes by patient characteristics, not provider characteristics.
2. *Variance reduction.* The classification should give minimum variation within each class and maximum variation across classes. Reduction in variation within classes is normally measured by the Coefficient of Variation (CV) measure, with the accepted standard being that each class should have a CV of less than 1.0. The reduction in variance (RIV) statistic is used to assess the overall performance of the classification, or parts of the classification. The more classes, the higher RIV one would expect to see. The level of RIV that can be achieved is also related to the amount of variation within the data that requires explanation. As noted above, the MH-CASC dataset was relatively homogeneous, compared with the variation observed in the more diverse general health sector. The best result that could be achieved could only be at the lower end of the RIV range achieved in the general health sector.
3. *Sensible clinical groups.* In order for a classification to be useful as a management information tool, the clinical groups should make sense to clinicians. Clinical factors have therefore to be balanced alongside statistical criteria.
4. *Ease of data collection.* The variables used to define the patient classes should be capable of routine data collection, coding and data entry, and ideally be a by-product of clinically related information needs.

Figure 5 presents a summary view of the setting-specific classification model. In total, the classification proposes 42 classes, accounting for 78% of the variance in episode costs at the 'top of the tree'. Of these, 23 are inpatient episodes (representing 79.8% of total expenditure) and 19 are community episodes (representing 20.2% of total expenditure). The five branches of the tree are based on the setting-specific episode types, each of which ultimately split into end classes on the basis of the indicated patient attributes.

Figure 5: Summary of MH-CASC setting-specific classification

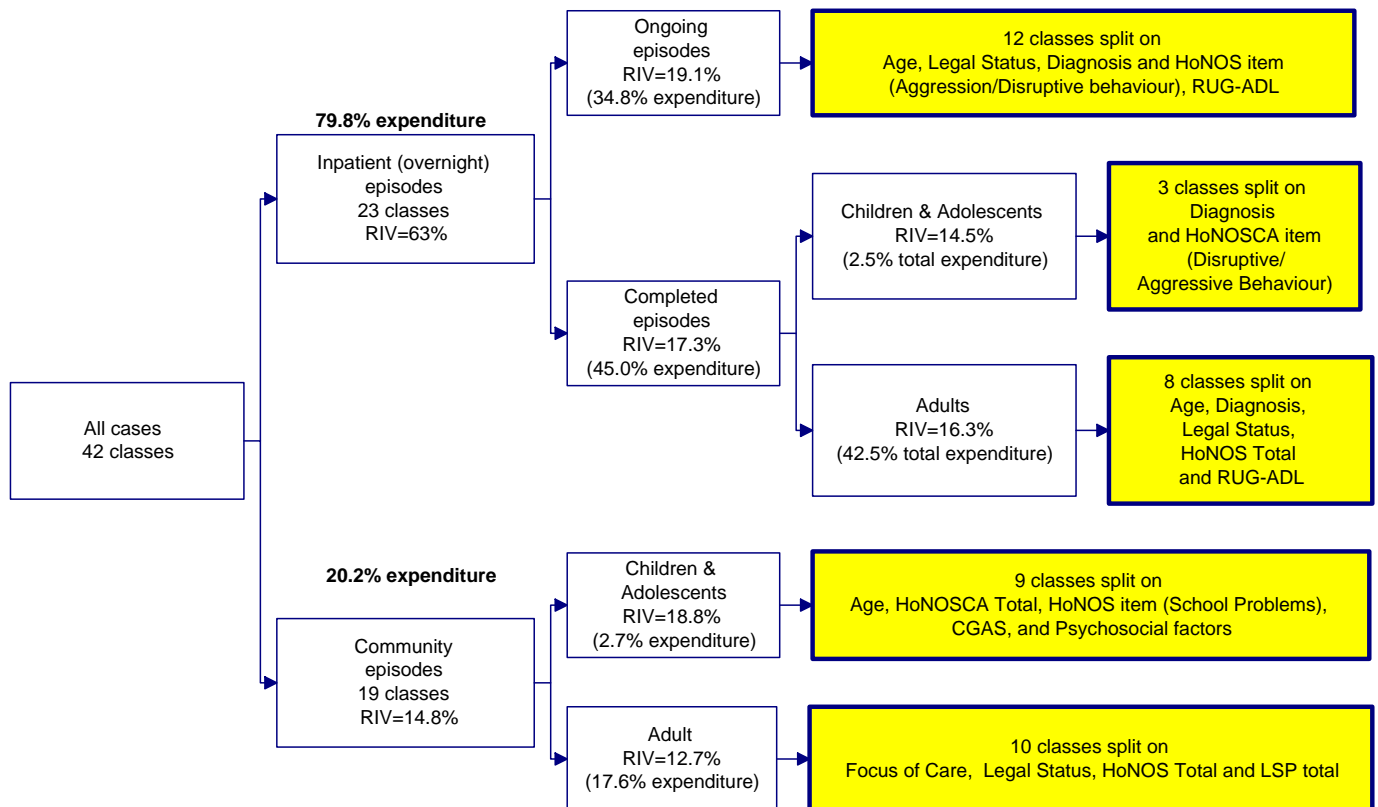

Adult Completed Inpatient Episodes

Patients in this cohort had an average age of 39.8 years; 11% were 65 years or older. Mood Disorders was the most frequent diagnosis recorded, accounting for approximately one third of episodes, followed by the Schizophrenia, Paranoia and Acute Psychotic Disorders diagnostic cluster.

Figure 6 summarises the Adult Completed Inpatient classification. The model assigns patients to 8 classes, accounting for 16.3% of variance. Classes are split on age, diagnosis, clinical severity, legal status and ADL dependency. Key features of the model include:

- The classes show a reasonable distribution in costs and lengths of stay. Fifty one per cent of cases are in the two low cost classes (Class ACI-1, \$2,484, and Class ACI-2, \$2,864) and the remaining cases are in classes with at least 53% higher than average costs (over \$4,386). The three highest cost classes (Classes ACI-5, ACI-7, and

ACI-8) have more than double the costs of the bottom two classes.

- Those patients with higher severity and dependency (measured by the HoNOS and RUG-ADL) and with involuntary status consume more resources than those patients with lower dependency and severity. The most expensive diagnostic groups are Schizophrenia, Mood Disorders, and Eating Disorders.
- Higher costs are associated with patients aged over 65 years, with people over 85 years comprising the most expensive class.
- Coefficients of variation range from 0.54 to 0.90, with most around the 0.7-0.8 level. These CVs are regarded as acceptable, and suggest that the classes are homogeneous.
- When the MH-CASC sample is scaled to the national level, the estimated number of people in each class is sufficient to satisfy the national standard of 200.

Figure 6: MH-CASC Classification Tree: Adult Completed Inpatient Episodes

8 classes, RIV=16.3% (trimmed), Episode Cost=\$3,900, LoS=12.4 days, Per Diem=\$331

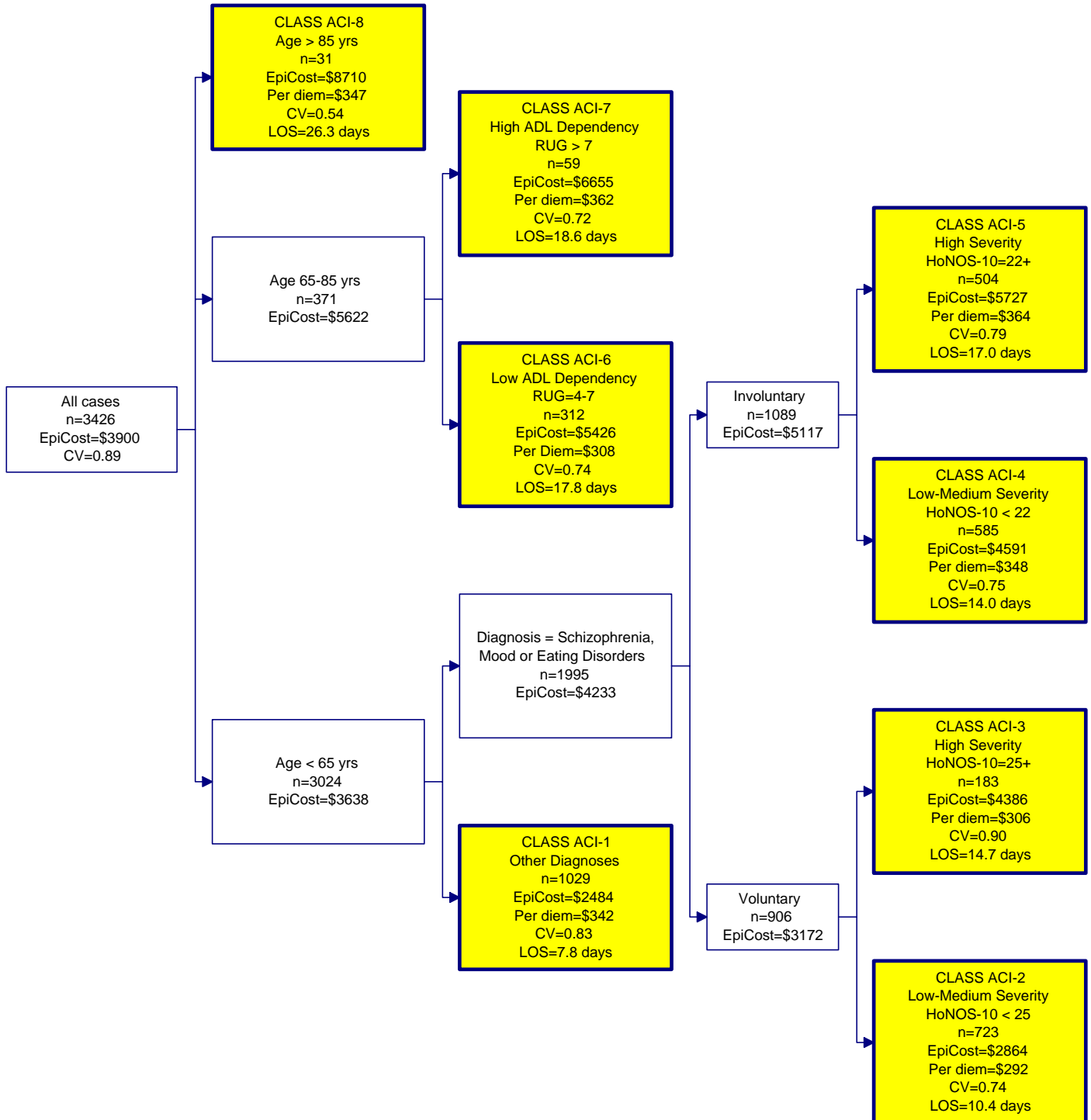

Adult Ongoing Inpatient Episodes

This group was significantly older than the completed inpatient cohort, with an average age of 53.7 years. Thirty-nine per cent of patients were 65 or more years old. Approximately two-thirds of patients were male. Schizophrenia, Paranoia, Acute Psychotic Disorders was the most frequent diagnostic category recorded for patients in the cohort, accounting for 55% of episodes, with Organic Disorders being the second largest group, accounting for 22% of episodes. As indicated earlier, the ongoing inpatient cohort had the most 'severe' problems, illustrated by their elevated HoNOS and LSP profiles.

Figure 7 summarises the Adult Ongoing Inpatient classification. The model proposes 12 classes, accounting for 19.1% of variance. Classes are split on age, diagnosis, legal status, aggressive/disruptive behaviour and ADL dependency. As with the Adult Completed inpatient classification, the classes have a clinical logic, with costs moving generally in the expected direction. Key features of the model include:

- Younger patients are more expensive, reflecting current practice that to be admitted to a non-acute inpatient unit a person now must need intensive support.
- Those patients with schizophrenia or organic disorder are less costly than patients with other diagnoses.
- For the young and middle-aged group, higher aggression and involuntary legal status are associated with more expensive episodes. Splits within the younger groups classes based on aggression/disruptive behaviour are consistent with a growing body of clinical research that indicates that young adult patients with high levels of aggressive or socially disruptive behaviour are replacing the older patient group in long stay psychiatric units. Recent research suggests that these patients account for a substantial proportion of the total mental health costs to the public health system.
- For the older group, Activities of Daily Living are the key differentiator, with

patients with higher ADL scores being more costly. This is consistent with experience in the general aged care health area.

- All classes have excellent CVs (mostly around 0.2), pointing to very resource homogeneous classes.

However, a defining characteristic of the adult ongoing inpatient cohort is the low level of variation between patients in costs (CV=0.32, untrimmed). Nevertheless, over a 12 month period, a long-stay unit would receive \$48,100 more for treating a person in the highest cost class compared with the lowest cost, an aspect that would be significant to funders.

Figure 7: MH-CASC Classification Tree: Adult Ongoing Inpatient Episodes

12 classes, RIV=19.1% (trimmed), 8-week period costs=\$13,722, Per Diem=\$254

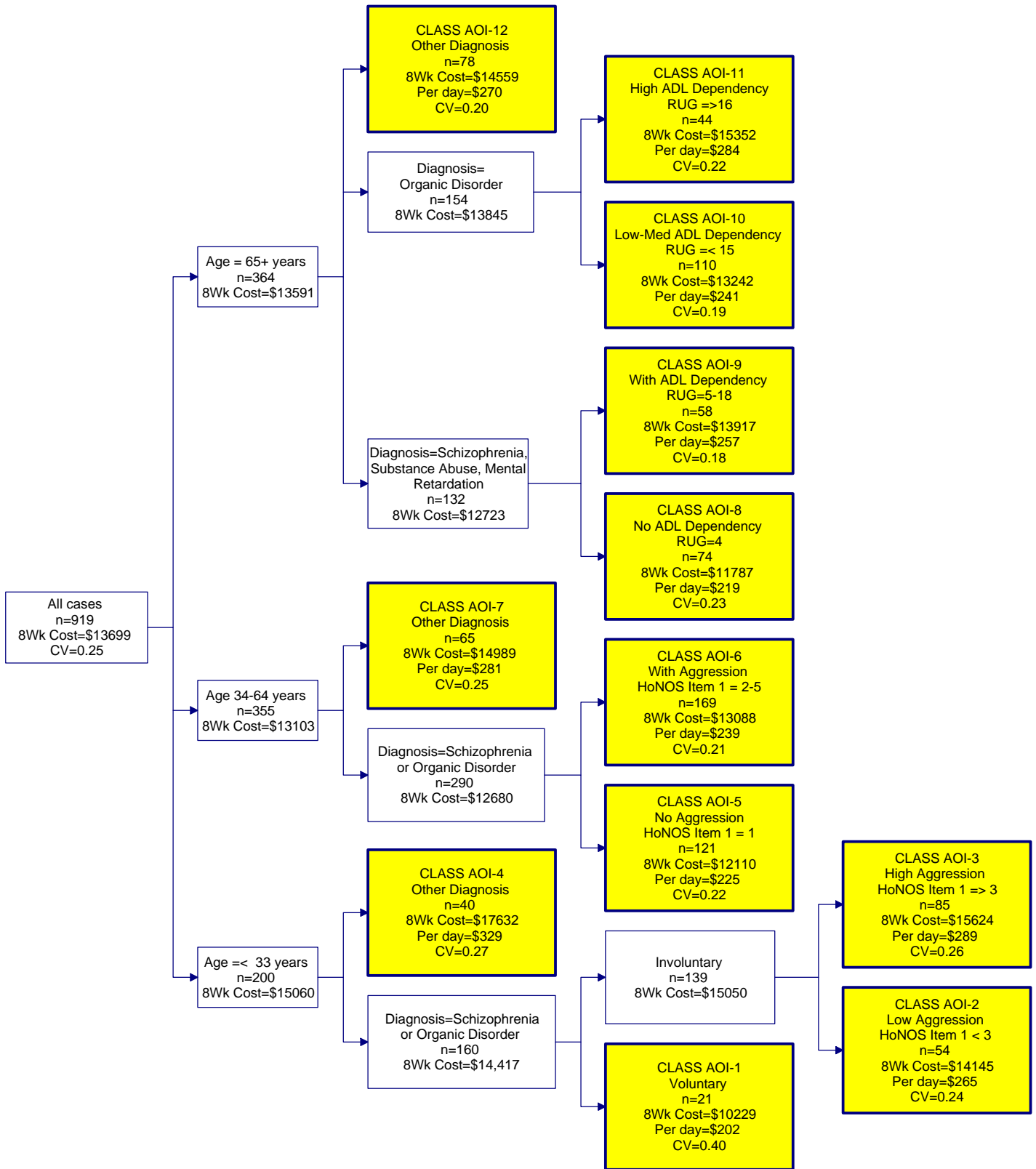

Adult Community Episodes

Patients treated in community services were similar to the adult completed inpatient cohort in their age and sex distributions. The average age of the cohort was 42.7 years, with 14.3% of episodes accounted for patients 65 years and older. The cohort comprised roughly equal numbers of men and women. Approximately 50% of episodes were accounted for by patients assigned a Principal Diagnosis of Schizophrenia, Paranoia, Acute Psychotic Disorders. Mood Disorders was the second most common diagnosis, accounting for 26% of episodes.

Explanation of variation in the community proved more difficult than in inpatient settings, possibly reflecting the greater complexity of community care. It is arguable that the inpatient environment is more controlled, with key decisions that drive resource consumption being more under the control of the service provider. A range of factors other than patient attributes may be important cost drivers in the community, such as the variable availability of core treatment programs (e.g., 24 hour crisis teams), variations in provider practice or the level of available social and family support.

Similar patient variables driving costs in the community are also important in the community (with the exception of diagnosis and ADL dependency) but, because the patterns of care are different, the relative importance of the variables differs across the two settings.

Figure 8 summarises the Adult Community Episode classification. The model proposes 10 classes, with splits on focus of care, legal status, clinical severity and disability. Although there is an underlying clinical logic to the community episodes classification, and the classes/costs move in 'the right direction', the overall statistical performance was only moderate. The CVs are acceptable at around 0.8, but the RIV is 12.7%. This suggests the groups are internally homogeneous, but not sufficiently

different from each other to achieve a high RIV.

Adult community episodes are much lower in cost than inpatient episodes, but are higher in volume, making the financial implications of applying the classification still significant. Key features of the model include:

- The highest cost episodes are for people with an intensive extended focus of care. The variable has clinical logic, identifying the group of the people living in the community who require constant follow-up if they are to continue outside the inpatient setting. The number of days on which treatment is provided for the intensive extended group with involuntary legal status is 11.9, nearly double the average community episode, and three times that provided to the lowest cost class.
- As in inpatient settings, the HoNOS proved to be a useful tool in explaining cost variation between patients. In the community, a group of 5 (out of the 12) HoNOS measures of clinical severity differentiated classes and costs, covering: Aggressive behaviour; Suicidal behaviours, Substance Abuse; Cognitive Problems; and Hallucinations and Delusions. The higher the score on these, the more a patient class costs in the community.
- Consistent with the clinician views, level of functioning or disability is also an important influence on costs in the community, as measured by the Life Skills Profile total score.
- The HoNOS clinical severity scales and Life Skills Profile interacts in a clinically logical manner. For example, the combination of moderate clinical severity/high disability costs almost twice the class with low clinical severity and low disability (\$572 and \$304 respectively).
- As with inpatient episodes, involuntary legal status is an important predictor of resource use.

Figure 8: MH-CASC Classification Tree: Adult Community Episodes

10 classes, RIV=12.7% (trimmed), 8-week period costs=\$526, Treatment Days=6.3, Per Diem=\$94

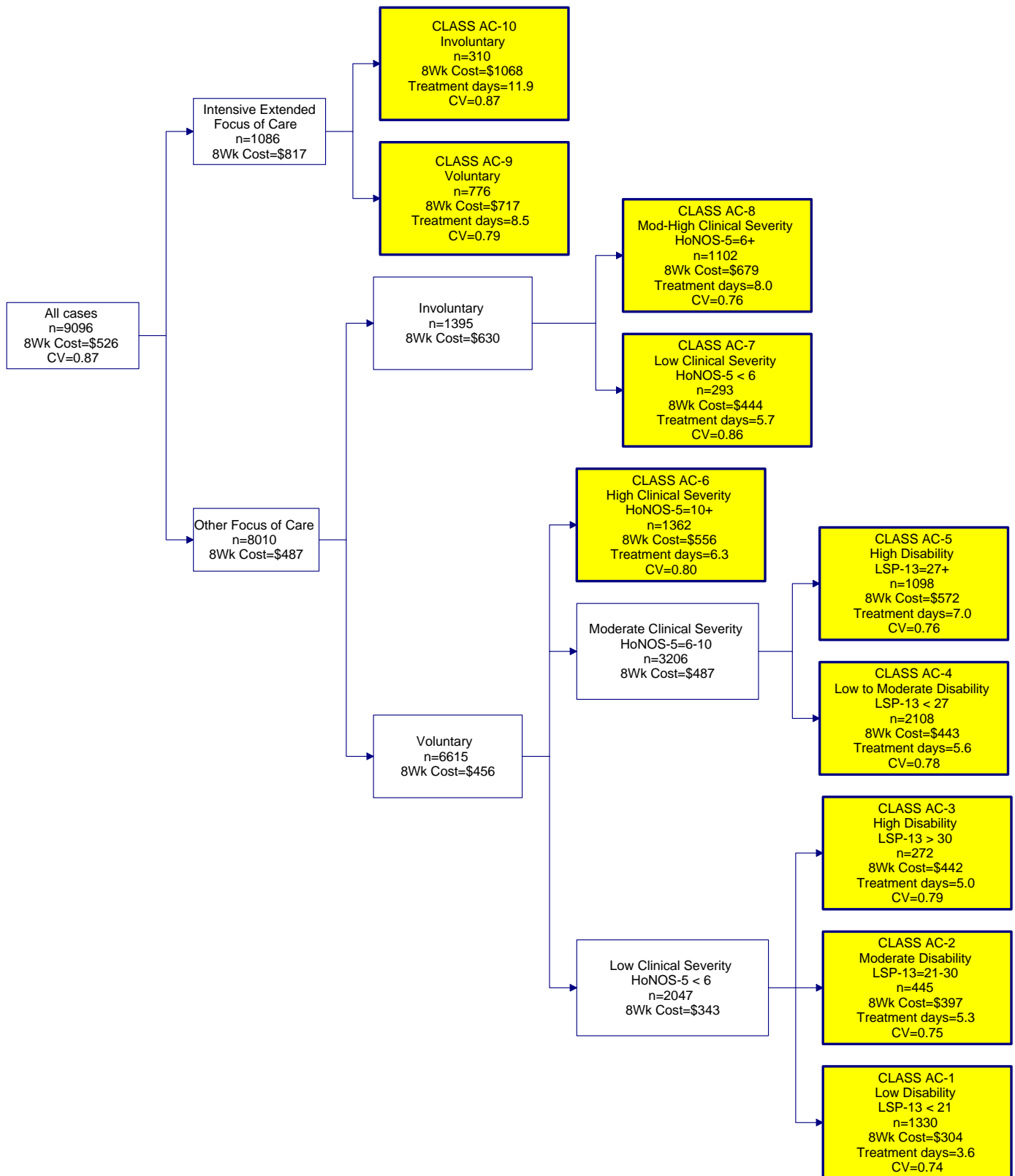

Child and Adolescent Completed Inpatient Episodes

The average age of this group was 14.4 years. The majority (59%) were adolescents in the 15-19 year age range. Depressive Disorders was the most frequent diagnosis recorded for patients in the cohort, accounting for 20% of episodes, followed by Mixed Disorders of Conduct and Emotions (16%). The low number of episodes in the child/adolescent inpatient sample limits the extent to which the diagnostic profile can be generalised.

For completed inpatient episodes only diagnosis and the disruptive/aggressive behaviour item of the HoNOSCA were used to create 3 classes. The trimmed RIV of 14.5% was comparable with the other classification branches of the MH-CASC model, and CVs around 0.7.

Figure summarises the key features of the model.

Child and Adolescent Community Episodes

Child and Adolescent patients treated in community services were, on the whole, a younger group than their inpatient counterparts, with an average age of 11.0 years (c.f. 14.4 for inpatients). Seventy two per cent of the cohort was 14 years or less. Approximately two out of every three patients were males. Mixed Disorders of Conduct and Emotions was the most frequent diagnosis recorded for Child and Adolescent community patients, accounting for 21% of episodes, followed by Conduct Disorders and Hyperkinetic disorders (9% each).

Figure 10 summarises the Child/ Adolescent Community Episode classification, with splits on age, severity, global functioning, psychosocial complications and a single HoNOSCA item (School Attendance Problems). These factors were identified by the clinical panels as likely to have significance in the child and adolescent area. The CVs were mostly around the 0.6-0.7 level, and RIV was 18.8% (trimmed), considerably above that achieved in the adult community branch of the model.

Figure 9: MH-CASC Classification Tree: Child and Adolescent Completed Inpatient Episodes

3 classes, RIV=14.5% (trimmed), Episode Cost=\$6,048, LoS=16.6 days, Per Diem=\$415

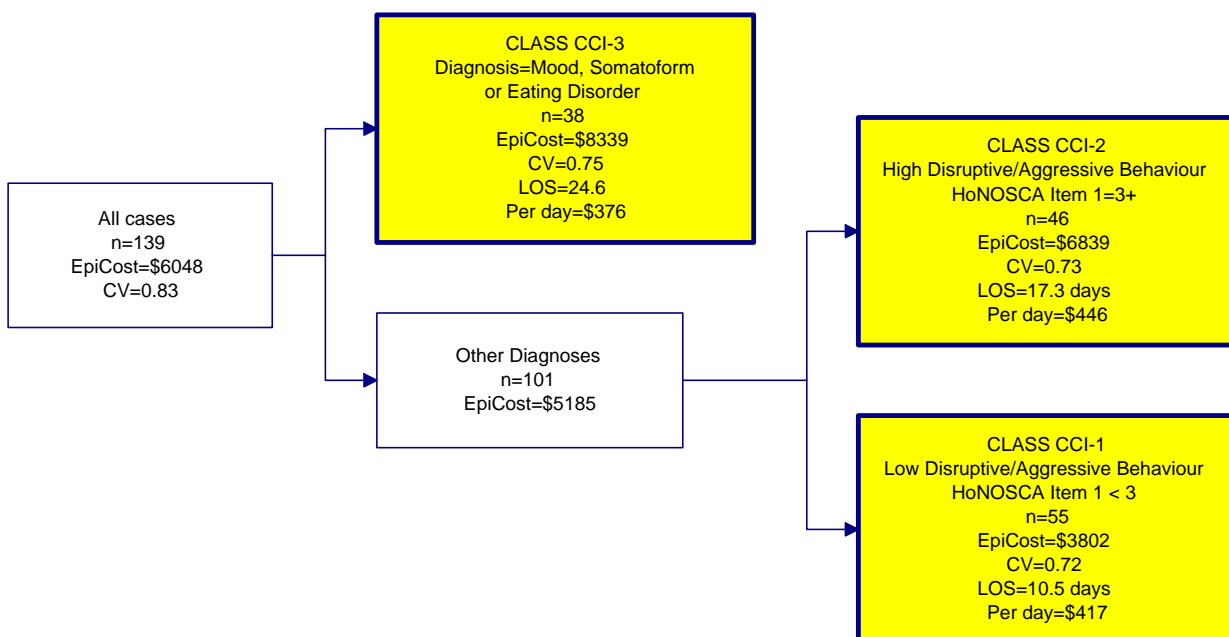
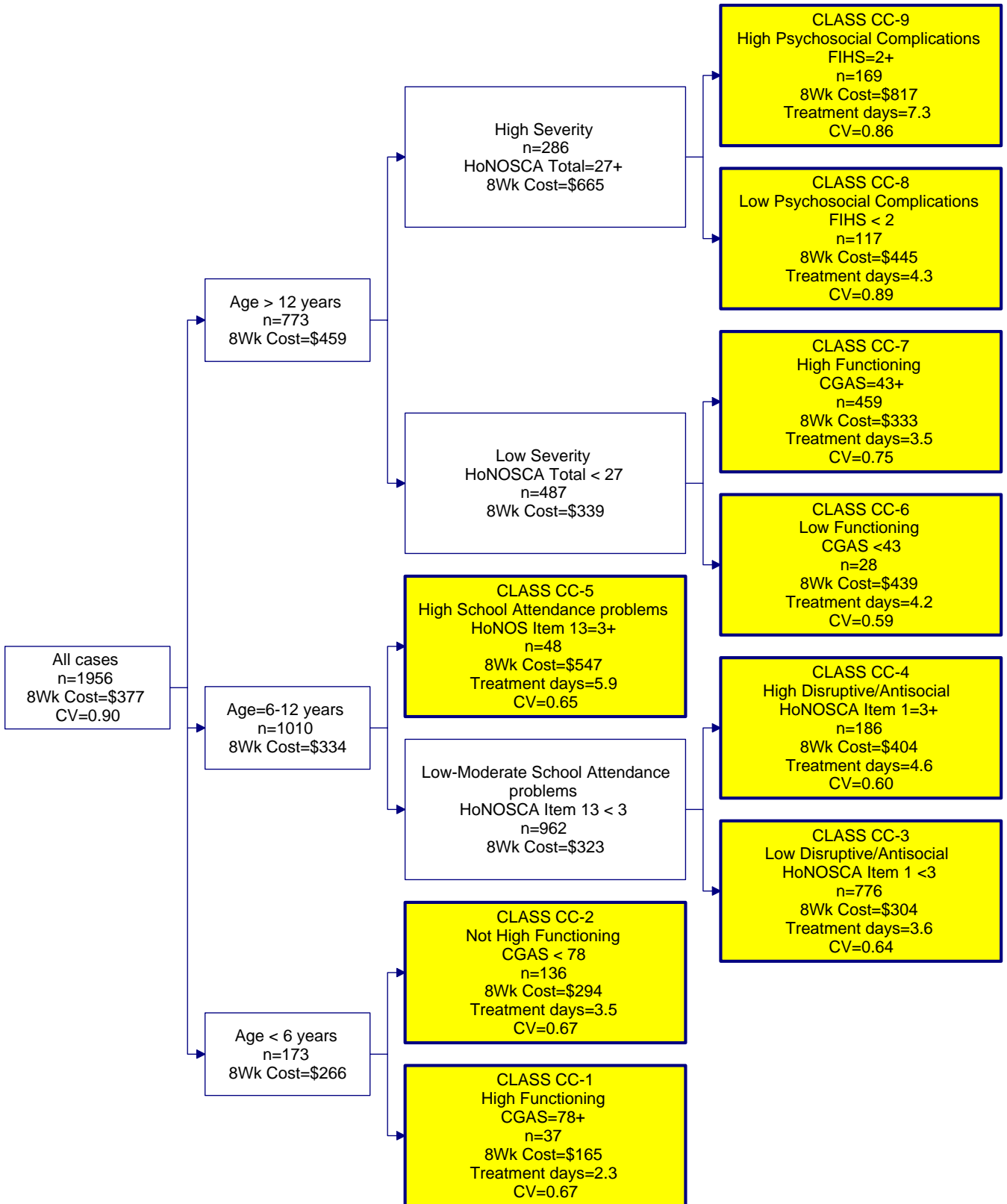

Figure 10: MH-CASC Classification Tree: Child/Adolescent Community Episodes

9 classes, RIV=18.8% (trimmed), 8-week period costs=\$377, Treatment Days=4.1, Per Diem=\$95



'Bundled Episodes'

Classification development in which episodes of care are defined across treatment settings is unexplored territory in Australian casemix research. Few precedents were available to guide the approach taken by the Project Team. The exploratory work undertaken in this area aimed to demonstrate the potential for further development of cross setting models.

Those patients in the adult patient cohort who were under care for a minimum of four weeks during the study period, and who were treated within integrated mental health sites, were included in the analysis cohort (n=8,067). For each patient, 8-week period costs were calculated, with upward and downward scaling applied to patients who were under care during the study for less than or greater than 8 weeks, respectively.

The optimum classification contained 12 classes that accounted for 27.9% of variation in the 8-week costs, using trimmed data. However, the statistical performance is below the setting-specific episode classification when trimming and CV levels are taken into consideration. Details of the classification are not presented in the summary, but can be found in the main report.

Three features of the classification are prominent. Firstly, there is considerable heterogeneity in the untrimmed cost data, primarily due to the fact that high cost admitted patients and low cost community patients have been brought together. Related to this, standard casemix trimming formulae bring the intra-group variation to reasonable levels, but exclude 10.8% of high cost cases. Finally, the imbalance in the volume of cases between the 12 classes is significant.

Patient variables found to predict 'bundled' 8-week costs included legal status, clinical severity, age, diagnosis, psychotic symptoms, suicide risk and aggressive/disruptive behaviour. Of these, legal status was the best single predictor of costs. However, in this analysis, legal status acted as a proxy to indicate whether the patient had been admitted for an inpatient stay. Inpatient status alone accounted for

42% of the variation in 8 week costs, but this was excluded from the analysis because it is a service attribute rather than a patient attribute. The preferred approach is to isolate those patient factors associated with inpatient status and involuntary legal status. Initial exploratory work to identify the clinical indicators of legal status was, however, unsuccessful.

Summary of patient cost drivers

In summary, the study found there is a clinically logical relationship between patient attributes and resource use in Australian mental health services. Patients who are expected to cost more usually do cost more.

Table 4 summarises the patient cost drivers found to be influential in each of the episode types.

Table 4: Patient cost drivers for each of the episode types

	Inpatient Episodes	Community Episodes
Adult services	<p><i>Completed Inpatient Episodes</i></p> <ul style="list-style-type: none"> • Age (very old = highest cost) • Diagnosis, with Schizophrenia, Mood and Eating disorders the highest costs • Overall severity (as measured by HoNOS total score) • Involuntary legal status • ADL dependency (for >65 years only) 	<ul style="list-style-type: none"> • Clinical Focus: Intensive Extended Care vs Other • Involuntary legal status • Overall clinical severity (as measured by HoNOS clinical scales) • Disability (as measured by LSP)
	<p><i>Ongoing Inpatient Episodes</i></p> <ul style="list-style-type: none"> • Age: Young adults more expensive (when combined with other attributes) • Diagnoses other than Schizophrenia and Organic Disorders associated with higher cost • Aggressive/disruptive behaviour • Involuntary legal status • ADL dependency (for > 65 years only) 	
Child and Adolescent Services	<p><i>Completed Inpatient Episodes</i></p> <ul style="list-style-type: none"> • Diagnosis: Mood, Eating and Somatoform disorders more expensive • Disruptive/Aggressive behaviour 	<ul style="list-style-type: none"> • Age: Distinguish pre-school, primary and secondary • Overall clinical severity • Level of functioning • Disruptive/aggressive behaviour • 'Psychosocial complications' • Problems at school

Comparative performance of the MH-CASC Classification Model

The AN-DRG3 classification offers the only benchmark for comparing the MH-CASC model. To place the MH-CASC finding alongside AN-DRG3, both adult and child & adolescent completed inpatient episodes were combined in the comparison samples.

Table 5 summarises the comparison of the two classification approaches. It indicates that the MH-CASC classification achieves both a higher RIV and lower CVs than those achieved by the AN-DRG3 model.

The 9.9% RIV finding, resulting from application of the AN-DRGs to the MH-CASC data set, is comparable with the 11.7% RIV published by the Australian Casemix Clinical Committee (ACCC). The ACCC used length of stay as the dependent

variable, and drew on the national hospital morbidity dataset, including non-specialised mental health services. Same day admissions were included in the ACCC analysis but excluded in the results presented in Table 5.

Subsequent adjustments to AN-DRGs for the fourth version used 'intended same day' status to partition episodes in the revised AN-DRG4, with RIV results of 35.6%. The MH-CASC dataset confirms this finding. When the MH-CASC cohort included the 'intended same day' group in the acute inpatient cohort, it found untrimmed RIV for AN-DRGs of 36.6% and a trimmed figure of 44.1%.

This line of analysis was not pursued in MH-CASC study, as Project Team decided that intended same day patients were more appropriately included in the community cohort. This decision was taken for several reasons.

Table 5: Comparison of AN-DRGs and MH-CASC classifications for Completed Inpatient Episode costs (adult and child/adolescent combined)

	AN-DRG	MH-CASC
Number of cases	2,541	3,758
Number of classes	8	11
Reduction in variance (RIV)		
- Untrimmed	3.8%	8.7%
- Trimmed	9.9%	17.3%
Range of Coefficient of Variance (CV)		
- Untrimmed	0.71 to 1.24	0.60 to 1.15
- Trimmed	0.63 to 1.15	0.54 to 0.90

First, there is ambiguity in how ‘intended same day’ is defined by mental health service agencies, with day programs being defined by some as community services and other as inpatient admissions. Second, data collected in the MH-CASC study revealed that there is no obvious difference between community and intended same day in the amount of treatment time provided to the patient. Third, use of same day inpatient classes could create a funding incentive to bring patients in for hospital based programs, rather than treat them in the community. Finally, the approach was considered to lack statistical credibility as it uses a dependent variable (one day length of stay) to predict a dependent variable (length of stay). The standard casemix approach uses patient characteristics as the independent variable, so that resource input (dependent variable) can be matched to patient need (independent variable).

The role of provider factors

Although patient factors were shown to drive costs, the “signal” was relatively weak. Other factors may have contributed to the study findings, such as variations in providers’ practices which was unrelated to clinical attributes of patients.

The variable ‘Site’, used as proxy for provider, was shown to be a significant predictor of patient cost variation, even after cost standardisation adjustments to reduce its effects. In isolation, this finding is ambiguous because they provide only indirect evidence of genuine provider

differences. It might be, for example, that ‘Site’ was a good predictor of costs because sites differed in their casemix.

For this reason, provider factors were explored further in an effort to disentangle the provider factors and patient factors more fully. This was done by examining the level of servicing to patients within one MH-CASC class. This method controls for variations between sites that are attributable to patient differences and allows provider variation to be isolated.

The class represented in Figure 6 with the code ACI-5 was selected as an example for study. This class comprises patients who are less than 65 years, have a diagnosis of schizophrenia, mood or eating disorders, have high clinical severity based on their HoNOS scores, and are placed on an involuntary treatment order at some point during the episode. After exclusion of private sites (which do not assign involuntary status) and trimmed cases, 499 patients in this class were examined.

Sixteen of the 22 study sites treated patients in this class. Table 6 summarises the episode costs and level of care provided at each of the sites.

The table shows a considerable range in episode costs, but it is the variation on the service indicators that point to inconsistencies in clinical practice. For example, length of stay ranged from 10.7 to 30.0 days, while the amount of clinical time dedicated to individual patients varied from 1.6 to 5.1 hours per day.

To add a broader context to the interpretation of the data, an indicator of the type of patients treated at each of the 16 sites has been added to each site in Table 6. The indicator, the Site Casemix Index, is an overall measure of the relative case complexity of patients, where the average of all sites is set at the value 1.0.

Thus, an index value of 1.1 for a particular site would indicate that patients treated at the site are 10% more complex than average.

Table 6: Site differences in the care of comparable patients
Adult Completed Inpatient Episodes, Class ACI-5
Age < 65 years, schizophrenia or mood or eating disorders, involuntary status, high severity

Site	Site Casemix Index (Adult Completed Inpatient Episodes)*	Cost per Episode	Length of Stay	Time per Day (Hours)
1	0.94	\$12,236	30.0	2.8
2	1.21	\$8,734	23.0	5.1
3	0.91	\$7,807	14.1	3.2
4	1.05	\$7,120	23.6	4.0
5	0.97	\$7,007	17.5	3.1
6	1.13	\$6,548	23.1	3.7
7	1.00	\$6,499	20.9	3.0
8	1.09	\$6,424	18.1	3.1
9	0.99	\$5,996	24.9	2.7
10	0.99	\$5,280	15.3	2.8
11	1.03	\$4,942	14.5	2.9
12	0.99	\$4,464	11.6	3.0
13	0.94	\$4,150	15.7	3.5
14	1.03	\$3,796	14.1	1.6
15	1.03	\$3,658	10.8	4.6
16	0.92	\$3,164	10.7	3.8
Average	1.00	\$5,727	17.0	3.1

* Note: The Site Casemix Index is an overall measure of the case complexity of patients treated at the site and is based on total volume adjusted for casemix. The Index is calculated by the following formula:

$$\text{Index} = \frac{\text{Sum of } \{(N \text{ Class 1 cases} \times \text{Cost Weight}) + (N \text{ Class 2 cases} \times \text{Cost Weight}) + \dots (N \text{ Class n cases} \times \text{Cost Weight})\}}{\text{Total Number of Cases}}$$

The purpose of adding this measure was to explore whether the variation between sites in the level of service provided to patients in the ACI-5 class was related to the overall demands upon the site. For example, it is conceivable that a site with more complex patients may be under greater pressure to 'ration' care to all patients than those sites with a less complex caseload.

No relationship is evident in the data presented in Table 6. For example, the overall casemix complexity for Site 1 was 6% less than the average (Casemix Index = 0.94). When this site treated patients in the ACI-5 class, it retained them in hospital for 30.0 days, 76% longer than the average for patients within this class. Yet at Site 13, with an equivalent casemix complexity index, patients were discharged in 15.7 days or 7.6% less than the average. Similar patients treated at Site 2, where the overall complexity of cases was 21% higher than average, received an average length of stay of 23.0 days, a finding that contradicts the hypothesis that units under greater casemix pressure will provide less care than those with a less complex caseload.

Some provider factors may be structural (e.g., types of service available, overall resource availability) and others may be under the control of individual clinicians (e.g., differences in clinical practices). Further work on the impact of levels of resourcing and service structures is required to disentangle these factors.

The challenge for the mental health community is to work together to strengthen the patient 'signal'. This may be assisted by a range of strategies, including clinical protocols developed by the professions, use of the MH-CASC classification for management information and review, and perhaps piloting of the classification for funding purposes.

Implications for funding and the National Mental Health Strategy

The MH-CASC Project has wide ranging implications for both the funding of mental health services and, more generally, the National Mental Health Strategy. Additionally, the MH-CASC classification model raises a number of issues that need to be considered as part of a general review of its suitability for use in a funding context.

The suitability of the MH-CASC classification for application

The central question to be asked of the Project is whether the MH-CASC classification model, developed from current patterns of service use, is suitable for use in a funding or management information context. There will be different views on this issue.

While the adoption of the classification is ultimately a decision for funders of mental health services, a range of issues should be considered in reaching a final judgement.

The most important of these concerns the purposes of a casemix classification. Casemix systems have become synonymous with funding models for health services in Australia. However, their origin was motivated not by a desire for new funding arrangements, but instead, by the need for tools to support quality assurance and utilisation review.

They do this by providing a method to describe the products of health care delivery that controls for differences between providers caused by those providers treating different types of patients. By controlling for patient differences, the contribution made by provider differences to patient costs and outcomes can be better understood.

It is important to recall that this was the development path taken with the AN-DRG classification in Australia, with it first being introduced in the mid 1980's for management purposes long before its application in a funding context. The experience gained through this process allowed clinical refinements and

improvements in precision to be made, along with modelling of the implications of using casemix for funding purposes.

In reviewing the early years of casemix in Australia, the March 1997 edition of the *Australian Casemix Bulletin* commented that the current Australian approach “... *did not emerge out of the ether fully formed. It was built on the foundations of many years thought, work and research.*”

The point here is that mental health services in Australia are only at an early stage of the casemix development cycle. The types of issues confronting the mental health industry, such as apparent wide variation between providers, the absence of clinical protocols, lack of national benchmarks and other tools to support service reforms, are comparable to those that initially drove the DRG development program. Distinguishing the role of a casemix classification in resolving these issues, from its more narrow use as a tool for funding, is critical in the decision about how to apply the MH-CASC classification model. Most important is the need to recognise that improvement only comes with practice experience, and that a start often needs to be made using imperfect solutions.

In deciding whether the MH-CASC classification should be pursued, national and state jurisdictions will need to assess the range of uses of the model. These include:

- **Funding purposes.** The utility of the classification for funding will need to be assessed by individual funding authorities, taking account of the adequacy of their existing approach to funding.

Funders are likely to be cautious of immediate use of the MH-CASC classification for funding purposes because of the comparatively low RIV statistics when compared with AN-DRGs for acute inpatient services. However, this will depend on whether they regard the current historical or input based funding as preferable.

As indicated in Table 5, the classification performs better than the AN-DRG mental health classification

both in terms of its capacity to explain patient cost variation and the statistical homogeneity of its classes. Perhaps more importantly, it provides coverage of both inpatient and community services, and avoids the potential for distorted incentives created when a classification is implemented that covers only the acute hospital sector.

In its current form, the classification is likely to be useful as a management and clinical information tool that can inform funding decisions by providing more information on who is receiving mental health resources.

- **Costing and benchmarking purposes.** The classification may be used to develop cost bench-marking information, enabling service agencies to make comparisons with other sites on the costs, length of stay and treatment days for similar cases. This can have an influence on practice, and by itself strengthen the statistical result of the classification.
- **Quality management.** Services may wish to collect the data to monitor the quality of services over time.
- **Clinical protocols.** The classification provides a base for the development of clinical protocols, in terms of establishing a framework for determining what package of services each group should receive. The objectives here would be to amplify the classification/costing signal, and encourage more normative practice.
- **Outcome measurement.** A longer term monitoring of clinical attributes will assist in determining the outcome of treatment interventions. Several of the measurement instruments upon which the classification is based were designed explicitly to monitor change over time.

Overall, the Project Team believes that the combined benefits to the National Mental Health Strategy of the MH-CASC model are sufficient to justify its adoption as the first version of an Australian mental health casemix classification.

Implications for data collection

The MH-CASC classification model has implications for data collection, since the majority of the variables which define the 42 MH-CASC patient classes are not routinely collected. Considerable change in collection and reporting arrangements would be required. Table 7 summarises the recommended data collection cycle required to implement the MH-CASC classification.

Further development of the classification

Ongoing refinement of the classification is necessary. Development work leading to the second version of the classification should include:

Clinical review and refinement. Similar clinical review processes should be put in place as those used for the ongoing refinement of the AN-DRG classification.

Relevance to the non-specialised mental health sector and linkages with other classification systems. MH-CASC was limited to specialised mental health services. As such, it is not possible to state whether the classification would perform in the same manner in mental health services provided within the general health sector. Given the mainstreaming objective of the National Mental Health Strategy, it would be desirable to explore this question. As an initial step, it would be valuable to determine how the MH-CASC classification interfaces with other classifications from different sectors, specifically AN-DRGs and AN-SNAP (Australian National Sub-Acute and Non-Acute Patients.)

The place of 'intended same day' admitted patients in the classification. 'Intended same' day admitted patients are included in the MH-CASC community classification, rather than with inpatient episodes, because the 'intended same day' and 'community' product looked similar to each other in terms of staff input. This deviates from the approach advocated by the Australian Casemix Clinical Committee in 1997 with regard to the revised Version 4 of AN-DRGs, which distinguishes them from community patients. To resolve this issue, the Project Team suggests that a review of a

representative sample of intended same day programs should be undertaken, both from a clinical 'appropriateness' and a costing perspective.

Relationship of episode costs to long term costs.

The construction of episode definitions for the MH-CASC classification was largely dictated by the 91 day study time frame. Further work is required to understand the relationship between the short term episode costs used in the MH-CASC classification and the long term care costs for individual patients. As a start, the care patterns of the MH-CASC patient cohort in the 12 months prior to and following the 12 month study period should be reviewed. Research of this type would require linkage of MH-CASC data with service utilisation data collections maintained at the site or State/Territory level.

Developing approaches for high cost outlier patients.

Trimming of high cost patients occurred post-class finding with an effect of reducing average costs for each of the classes. Trimmed cases ranged from 3.2% of Adult Ongoing Inpatient Episodes to 7.2% of Adult Community Episodes. While trimming is an accepted procedure to achieve more reliable estimates of average costs, value is likely to be gained from a specific study of high cost patients. Special arrangements would be required for dealing with 'outliers' should the MH-CASC classification be implemented in a funding model. Further work is required to unravel the distinguishing features of exceptional cost patients and explore the relationship between exceptional episode costs and longer term costs.

Table 7: Recommended data collection cycle required to assign episodes to classes within the MH-CASC classification

Adult Mental Health Services :	
<p>a. Inpatient settings</p> <p>Age RUG-ADL (for over 65 years only – within 24 hours of admission)</p> <p>Health of the Nation Outcome Scales Legal Status</p> <p>Principal Diagnosis</p>	<p>Data collected at:</p> <p>At admission</p> <p>14 days following admission, or discharge if this occurs sooner.</p> <p>If Episode continues beyond three months:</p> <ul style="list-style-type: none"> • reassess at three months and • repeat at 3 monthly intervals thereafter; and • repeat at discharge. <p>At discharge.</p> <p>If Episode continues beyond three months:</p> <ul style="list-style-type: none"> • collect at three months and • repeat at 3 monthly intervals thereafter; and • repeat at discharge.
<p>b. Community settings</p> <p>Age</p> <p>Health of the Nation Outcome Scales Focus of Care Legal Status Life Skills Profile (abbreviated version)</p>	<p>Data collected at:</p> <p>At registration</p> <p>4 weeks following registration, or discharge from care if occurs sooner.</p> <p>If Episode continues beyond 3 months:</p> <ul style="list-style-type: none"> • reassess at 3 months; and • repeat at 3 monthly intervals thereafter; and • repeat at discharge from care.
Child and Adolescent Psychiatry Services	
<p>a. Inpatient settings</p> <p>Health of the Nation Outcome Scales for Children & Adolescents Principal Diagnosis</p>	<p>Data collected at:</p> <p>14 days following admission, or discharge if occurs sooner.</p> <p><i>Note: Collection requirements for ongoing inpatients to be resolved.</i></p>
<p>b. Community settings</p> <p>Age Health of the Nation Outcome Scales for Children & Adolescents Chidrens Global Assessment of Functioning ICD-10 Factors Influencing Health Status</p>	<p>Data collected at:</p> <p>4 weeks following registration, or discharge from care if occurs sooner.</p> <p>If Episode continues beyond 3 months:</p> <ul style="list-style-type: none"> • reassess at 3 months; and • repeat at 3 monthly intervals thereafter; and • repeat at discharge from care.

Using the classification for cost benchmarking.

Three issues should be considered in using costs reported in the MH-CASC study to establish costing benchmarks: (1) adjustments would need to be made to reflect the exclusion of non-core costs such as pharmacy, which are estimated to account for 5-8% of total costs; (2) adjustments would need to be made for the fact that labour costs were standardised; and (3) agreement would need to be reached about how best to trim the data to reflect average costs.

Using the classification for ‘good practice costing’.

The MH-CASC classification is based on the costs of ‘average practice’ as it existed in late 1996. Concerns have been raised about using this as a base to fund future services, as it may not be consistent with ‘appropriate practice’. To test the validity of this concern, consideration should be given to using the MH-CASC classification to establish cost estimates for each of the classes based on ‘good practice’ clinical protocols.

Next steps for development of ‘bundled care’ concepts and other approaches to support service substitution.

The short timeframe of the study, along with the diverse types of multi-episode sequences, limited the Project’s initial ambition to develop a classification that would provide a financial incentive for substitution of inpatient admission by community care. Further work may point to greater opportunities for bundling care. For example, a pilot study could be conducted, in which collection of patient attribute data and number of treatment days could be collected. Alternatively, jurisdictions with comprehensive databases could examine the service utilisation pattern of those in the MH-CASC dataset to determine twelve month profiles.

Use of Age, Legal Status and Focus of Care.

Three of the variables used to differentiate patient classes are subject to debate:

- *Age:* The Adult Inpatient (Ongoing and Complete) and Child/Adolescent episode types use Age as a top-level splitting variable. Age is also used as a splitting variable in AN-DRGs. There is

concern that this is a relatively arbitrary split, and the person’s need for care (and associated reimbursement) should be linked more directly to clinical factors. The alternative view is that broad Age groupings do make clinical sense (e.g., the care needs of a younger person with schizophrenia or mood disorder are different from those of an older person). An important aspect of the ongoing clinical review of the MH-CASC classification is to confirm whether there is broad support for the use of Age as a classification variable.

- *Legal Status:* Legal Status is a key classification variable in all Adult episode types. It is also included in the fourth Version of the AN-DRG classification. There is concern that the use of Legal Status for funding may create an incentive for people to be classified as involuntary to receive higher reimbursement. The contrary view is that the administrative requirements of mental health legislation are such that clinicians are unlikely to take such action, and their professional ethic is to use Legal Status only if it is clearly necessary. The preferred option would be to find the mix of clinical factors that underlie involuntary Legal Status. Further work is needed to ‘unbundle’ the clinical attributes associated with involuntary mental health care.
- *Focus of Care:* Focus of Care was excluded as a classification variable in all episode types except Adult Community Episodes due to concern about the measure’s ‘hybrid’ status (in that it combined elements of the independent variable set with elements of the dependent variable set), a belief that it may be easily ‘gamed’ if applied in a funding context, and concerns that its psychometric properties were unknown. As with Legal Status, the preference would be to find clinical attributes that correlate with it. Further work is needed to refine and test the variable, or to determine the clinical factors that underlie it.

Refinement of the patient measurement instruments. The majority of the measures used in the MH-CASC classification are captured by rating instruments developed for other purposes. These need to be subject to ongoing refinement based on experience in their use.

Children and adolescents in ongoing inpatient care. In the MH-CASC Project, no attempt was made to classify people with ongoing episodes in child/adolescent specialist mental health services, due to their small numbers. However, it is recognised that such a group exists and has a genuine need for such ongoing care. Consultation with experts is required to determine the most appropriate way to fund this group.

Approaches for patient care activities outside the scope of the classification. All four non-patient attributable activities (services to unregistered clients; teaching, training and research; consultation-liaison services; and community development) would fall outside the boundaries of any funding system that allocated resources solely on the basis of casemix output. Separate funding options need to be developed for these ‘products’.

Suggestions for funding model design

Although the aim of the Project was to develop a classification system for mental health, the Project Team believes that the research work has a number of pointers for future funding model design:

1. There remains considerable scope for substitution between acute inpatient and community care, and a high risk of distorted incentives if only one service type is funded using casemix. If acute specialised mental health services are to be funded on an activity-basis (whether through AN-DRGs or the MH-CASC classification), then the MH-CASC classification model should also be used to fund community mental health services.
2. Design of any activity-based funding system for the community should be based on the number of services a person receives in a time period, not

the cost per occasion of service. Defined periods of time should be the basis for funding community programs.

3. The study has identified those clinical factors that predict hospitalisation, which may be useful for utilisation review.
4. Funding of an ‘intended same day admitted’ patient class or episode type should be avoided.
5. Per diem funding should be used to fund non-acute inpatient services, and not completed episodes of care.
6. The early days of ‘acute’ inpatient stays do cost more than later days, but not enough to justify a step-down funding system.
7. The data collected during the MH-CASC study do not support funding models which make reimbursement contingent on changes in outcomes as measured by current instruments.
8. If casemix funding is introduced to specialised mental health services, then there are other services or ‘product lines’ that need to be funded apart from casemix, specifically: brief assessments; consultation-liaison; teaching, training and research; and community development.

Strengthening the signal

The major challenge for the mental health community is to strengthen the signal so that there is a more normative pattern of service that differentiates the types of patients using specialised mental health services.

Casemix tools could greatly assist this work to proceed, because they provide a system to describe patients in a way that makes sense clinically, and which has meaning in terms of resource utilisation. It is not possible to disentangle the role of provider factors from patient factors without some standard system to compare patients. Similarly, a patient classification system is the starting point for development of clinical protocols.

The MH-CASC classification provides a basis for further development of normative patterns of care based on the attributes of people with mental disorders using specialised mental health services. There are a number of initiatives that could be contemplated:

- Use of the classification for management information, benchmarking, outcome measurement and quality review is likely to focus services more directly on the patterns of care being provided to different types of patients. Implementing routine collection of the MH-CASC patient dataset, and collation and publication of the data by a national benchmarking unit, could be considered.
- The professional colleges, in collaboration with State and Territory mental health units, could be funded to develop clinical protocols or pathways. The service utilisation patterns for the MH-CASC patient classes are a valuable resource in identifying the type, level, and cost of service over the three-month period of the study. The colleges could compare this with what is regarded as appropriate practice. The MH-CASC database is structured to allow future analyses of these patterns.
- Some sites could be selected for pilot collection of the patient attribute data for grouping into the MH-CASC classes and modeling the impact of their use for funding purposes. Sites that participated in the study would have the relevant training and expertise for this. Such a pilot should look at more long-term service utilisation patterns, and changes in clinical ratings over time, to enable further development of the bundling option.

Classification development, refinement and implementation are iterative processes. The above list is clearly not exhaustive, and other possibilities will emerge as the mental health industry gains experience in this area. The MH-CASC classification offers a potential base for many future developments in the mental health sector.

The MH-CASC Project Team

The MH-CASC Project Team comprised a consortium of individuals, drawn from several organisations, who came together specifically to conduct the Project under the management of the consulting company, Shane Solomon & Associates Pty Ltd. The team personnel and their respective roles are listed below.

Person	Project Role	Organisation
Mr Shane Solomon	Project Director	Principal, Shane Solomon & Associates Pty Ltd Currently Group CEO, Mercy Health and Aged Care
Mr Bill Buckingham	Principal Consultant	Principal, Bill Buckingham and Associates Pty Ltd
Assoc Prof Philip Burgess	Principal Researcher	Head, Policy & Analysis Group, Mental Health Research Institute of Victoria
Assoc Prof Kathy Eagar	Consultant, all aspects of study	Director of the Centre for Health Services Development, University of Wollongong Principal, Kathy Eagar and Associates Pty Ltd
Ms Jane Pirkis	Consultant, study design, site coordination, data analysis, report preparation.	Consultant, Centre for Health Program Evaluation, University of Melbourne
Ms Rita Brewerton	Costing Director	Principal, Brewerton and Associates Pty Ltd
Mr Adam Clarke	Consultant, data base development	Principal, Strategic Data Pty Ltd
Ms Amanda Price	Consultant, study design and clinical measurement	Principal, Strategic Data Pty Ltd
Ms Helen McCluskey	Consultant, Costing	Principal, McCluskey-Chen & Associates Pty Ltd
Ms Jenni Bowen	Consultant, Costing	Consultant, Brewerton and Associates Pty Ltd
Mr Bernie McKay	Consultant	Principal, Bernie McKay and Associates Pty Ltd
Dr Thomas McGuire	Consultant, Data analysis	Principal, Analytic Solutions, Inc
Dr Alan Rosen	Chair, Clinical Reference Group	Royal North Shore Hospital and Community Mental Health Service, New South Wales
Ms Sandra Padova	Executive Officer	Currently Executive Officer, Early Psychosis Program, Victoria

Terminology

Definitions marked with an asterisk have been taken, or adapted from the definitions in the Australian Casemix Report on Hospital Activity 1995-96 prepared by the Commonwealth Department of Health and Family Services.

*Diagnosis Related Group (DRG)**

A class of health service users with similar clinical conditions and service use needs. As the name suggests, the principal defining characteristic is usually the patient's diagnosis, but other factors such as comorbidity and complications are often taken into account. DRGs were developed for use in acute inpatient settings.

*Australian National Diagnosis Related Group (AN-DRG)**

A DRG system developed for use in Australia. Within the AN-DRG system, individual DRGs are grouped into Major Diagnostic Categories (MDCs) such as Diseases and Disorders of the Eye (MDC 2) or Injuries, Poisonings and Toxic Effects of Drugs (MDC 21). Mental Disorders form MDC 19.

Major Diagnostic Category

A high level grouping of patients according to principal diagnoses used in the DRG casemix classification. The AN-DRG classification is grouped into 23 MDCs.

*Coefficient of Variation (CV)**

The Coefficient of Variation is a number representing the dispersion around the average in a data sample, calculated by the standard deviation divided by the arithmetic mean. The larger the coefficient, the greater the variability around the average.

Reduction of Variance (RIV)

The reduction of variance statistic is used to assess the overall performance of the classification, or parts of the classification. Expressed in percentage terms, it represents the degree to which the classification reduces the amount of variation within the data sample.

*Trimming**

The process of removing unusual cases prior to production of statistics. For example, analysis of trimmed DRG data would involve removal of patients who were in hospital for unusually short or long periods. In the MH-CASC Project, similar to other studies of mental health care, the distribution of costs was found to be significantly skewed such that 'outliers' could only be reliably identified at the high cost end. Trimming therefore only involved removal of exceptionally high cost patients.